

銘傳大學 98 學年度研究所碩士班招生考試

電子工程學系碩士班

第三節

電子學試題

(第 1 頁共 2 頁) (限用答案本作答)

可使用計算機 不可使用計算機

- All transistors in the N output current mirror in Figure 1 are matched, with a finite β and $V_A = \infty$. If the circuit parameters are $V^+ = 5$ V and $V^- = -5$ V, and the transistor parameter is $\beta = 50$, determine R_1 such that each load current is 0.5 mA for $N = 5$. Assume that $V_{EB}(Q_R) = V_{BE}(Q_S) = 0.7$ V. (10%)
- Consider the circuit in Figure 2. Assume ideal op-amps are used. Derive the expression for the current i_O as a function of the input voltage v_i . (10%)
- For the FET circuit in Figure 3, the transistor parameters are: $K_n = 1$ mA/V², $V_{TN} = 2$ V, $\lambda = 0$, $C_{gs} = 5$ pF, and $C_{gd} = 1$ pF.
 - Calculate the equivalent Miller capacitance. (5%)
 - Determine the upper 3 dB frequency for the small-signal voltage gain and find the midband voltage gain. (20%)
- The ac equivalent circuit of a CMOS common-source amplifier is shown in Figure 4. The transistor parameters for M_1 are $V_{TN} = 0.5$ V, $k'_n = 85$ μ A/V², $(W/L)_1 = 50$, and $\lambda = 0.05$ V⁻¹, and for M_2 and M_3 are $V_{TP} = -0.5$ V, $k'_p = 40$ μ A/V², $(W/L)_{2,3} = 50$, and $\lambda = 0.075$ V⁻¹. Determine the small-signal voltage gain. (10%)
- The transistor in the source-follower circuit in Figure 5 has parameters $K_p = 2$ mA/V², $V_{TP} = -2$ V, and $\lambda = 0.02$ V⁻¹. The circuit parameters are: $R_L = 4$ k Ω , $R_S = 4$ k Ω , $R_I = 1.24$ M Ω , and $R_2 = 396$ k Ω .
 - Calculate I_{DQ} . (5%)
 - Determine the small-signal gains $A_v = v_o/v_i$ and $A_i = i_o/i_i$, and the output resistance R_o . (25%)
- Consider the circuit shown in Figure 6. The transistor has parameters $\beta = 60$ and $V_A = \infty$.
 - Determine the quiescent value V_{CEQ} . (5%)
 - Determine the small-signal voltage gain $A_v = v_o/v_s$. (10%)

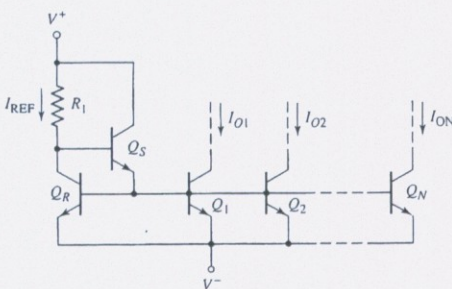

Figure 1

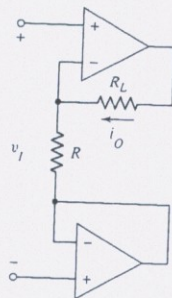

Figure 2

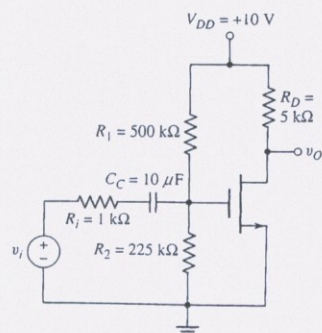

Figure 3

銘傳大學 98 學年度研究所碩士班招生考試

電子工程學系碩士班

第三節

電子學試題

(第 2 頁共 2 頁) (限用答案本作答)

可使用計算機 不可使用計算機

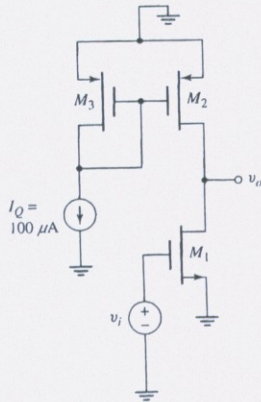

Figure 4

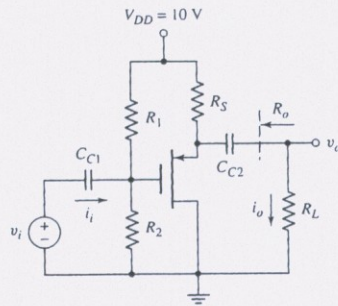

Figure 5

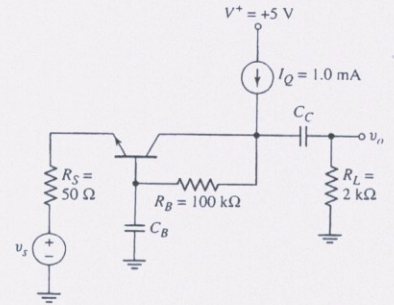

Figure 6

本試題兩面印刷

試題完